

4

3

2

1

B

B

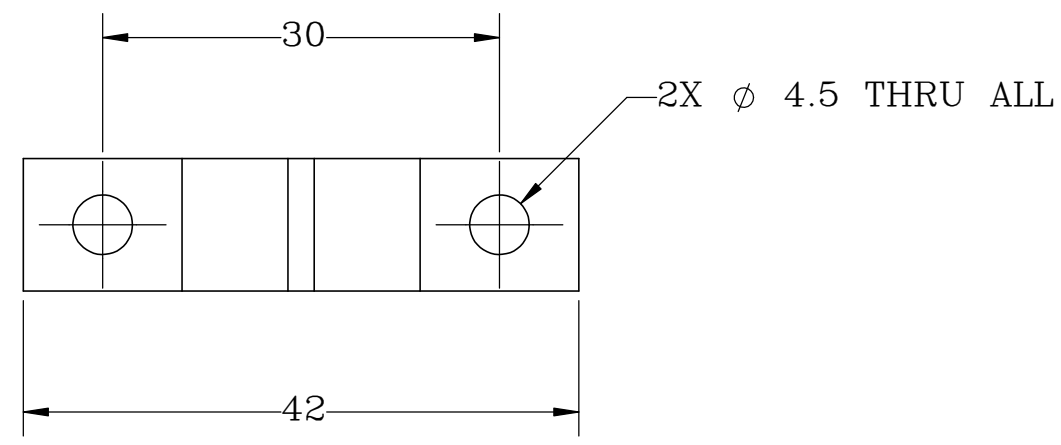
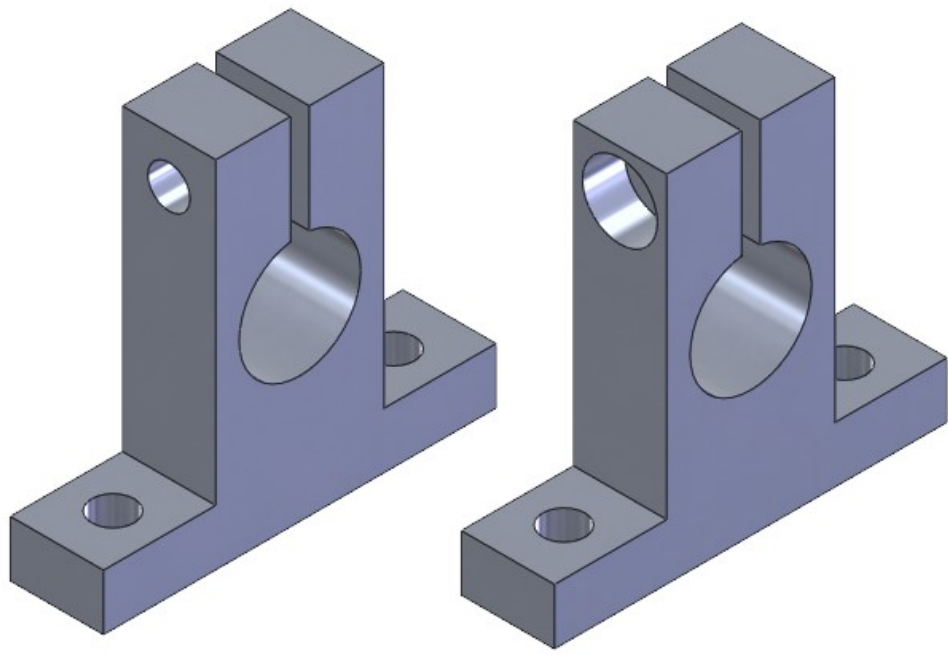

A

A

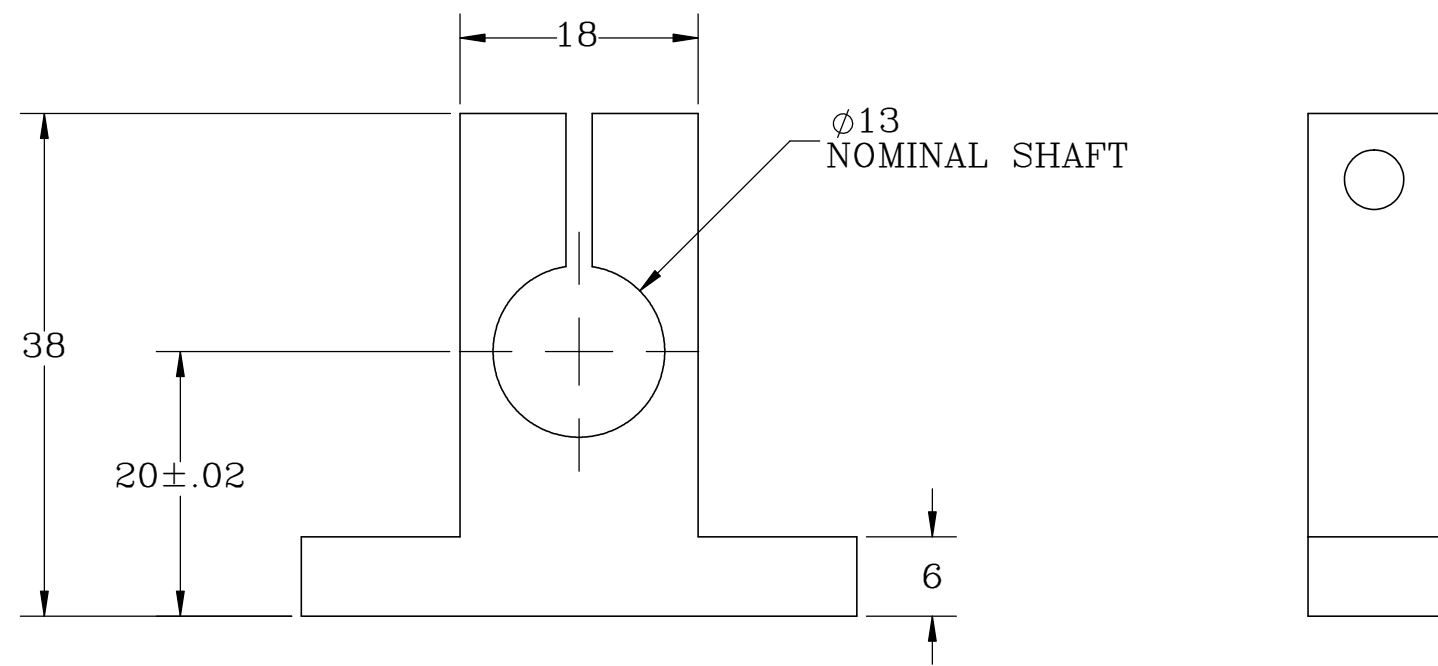
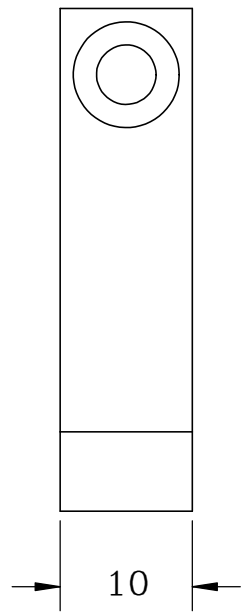

NOTES:

- 1. ALL DIMENSIONS ARE IN MM.
- 2. TIGHTENING SCREW: M4 SOCKET HEAD CAP SCREW.

PROPRIETARY ITEM:  
 THIS DRAWING CONTAINS  
 INFORMATION PROPRIETARY TO NEW  
 WAY MACHINE COMPONENTS, INC. ANY  
 REPRODUCTION, DISCLOSURE, OR USE  
 OF THIS DRAWING OR THE  
 INFORMATION CONTAINED HEREIN  
 IS EXPRESSLY PROHIBITED EXCEPT AS  
 NEW WAY MAY OTHERWISE AGREE TO  
 IN WRITING. ALL RIGHTS RESERVED BY  
 NEW WAY MACHINE COMPONENTS, INC.

TOLERANCES UNLESS OTHERWISE SPECIFIED ANGLES: $\pm 1/2^\circ$ DECIMALS: XX $\pm .01$ XXX $\pm .005$ FRACTIONS: $\pm 1/64$ SURFACE ROUGHNESS: $\sqrt{\text{RMS MAX}}$ BREAK ALL SHARP EDGES: .005-.020	TITLE: 13mm END MOUNT			
	DRAWN: MB	DATE: 08/24/21		
	CHECKED: MTS	DATE: 09/23/21	HEAT TREAT: -	
	SCALE: 1:1	SHT. 1 OF 1	FINISH: CLEAR ANODIZE	
USED ON (NW #): -		DWG. #	S8013E02	REV. -

4

3

2

1